

## 89181211-SF

### 12V Dual Fan Condenser

- Stainless Steel Finish
- Bracketless Mounting
- Sprinter Van Compatible

Part of the...

**SNOWBIRD** SERIES

...of products

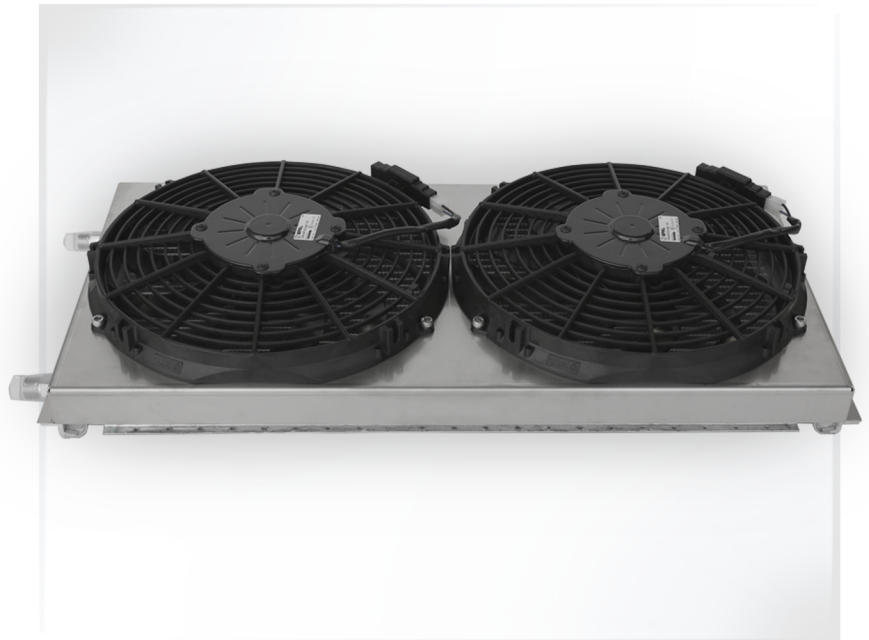

## 89181211-SF SPECIFICATIONS

**CAPACITY:** Cooling 32,690 BTUH (9.58 kW)

**WEIGHT:** 16.5 lbs (7.5 kg)

**AIR FLOW:** 823 CFM (23.4 CMM)

**CURRENT DRAW:** 15.2 Amp Draw

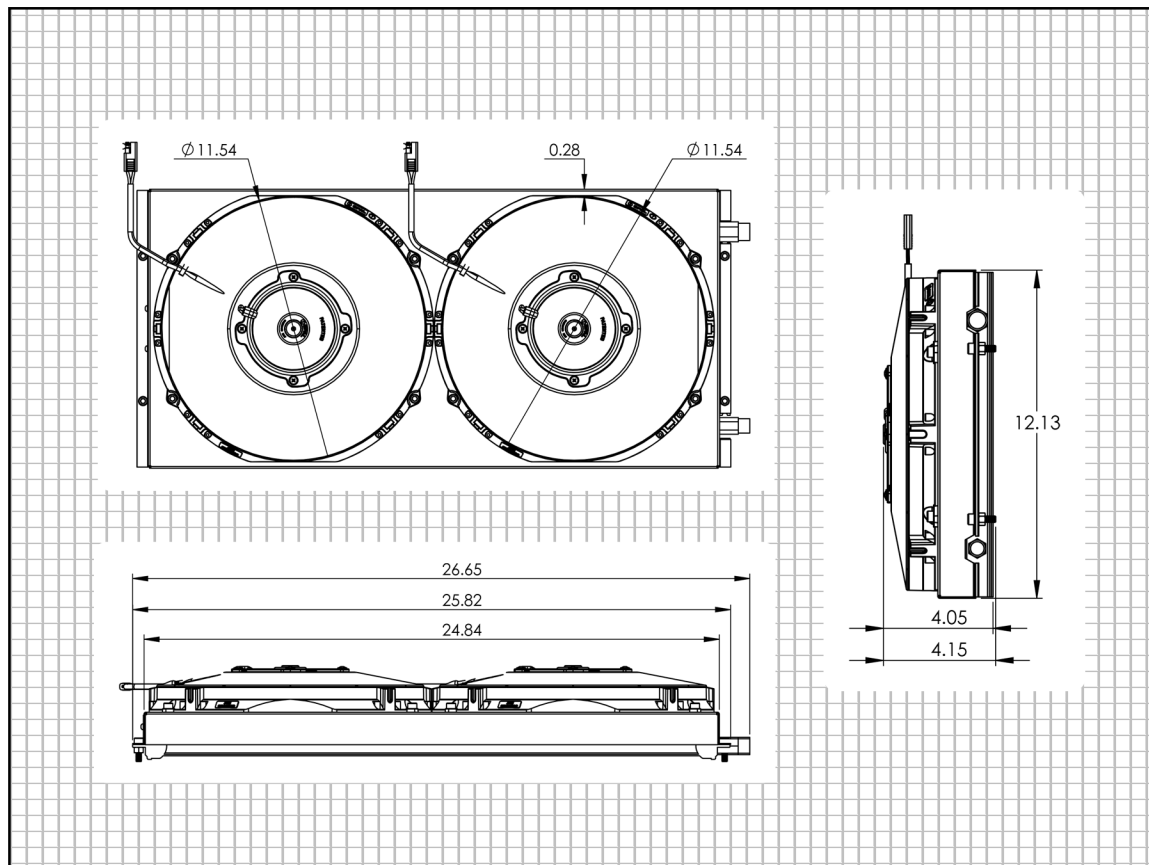

### PRODUCT DIMENSIONS

**Width:**  
26.65 in  
[676.91 mm]

**Height:**  
4.15 in  
[105.41 mm]

**Depth:**  
12.13 in  
[308.10 mm]

SCAN FOR MORE INFORMATION

