

89181202-SF

12V Dual Fan Condenser

- Stainless Steel finish
- Black finish also available (89181202)

Part of the...

SNOWBIRD SERIES

...of products



89181202-SF SPECIFICATIONS

CAPACITY: Cooling 29,719 BTUH (8.7 kW)

WEIGHT: 16.5 lbs (7.5 kg)

AIR FLOW: 1353 CFM (38.31 CMM)

CURRENT DRAW: 16.6 Amp Draw

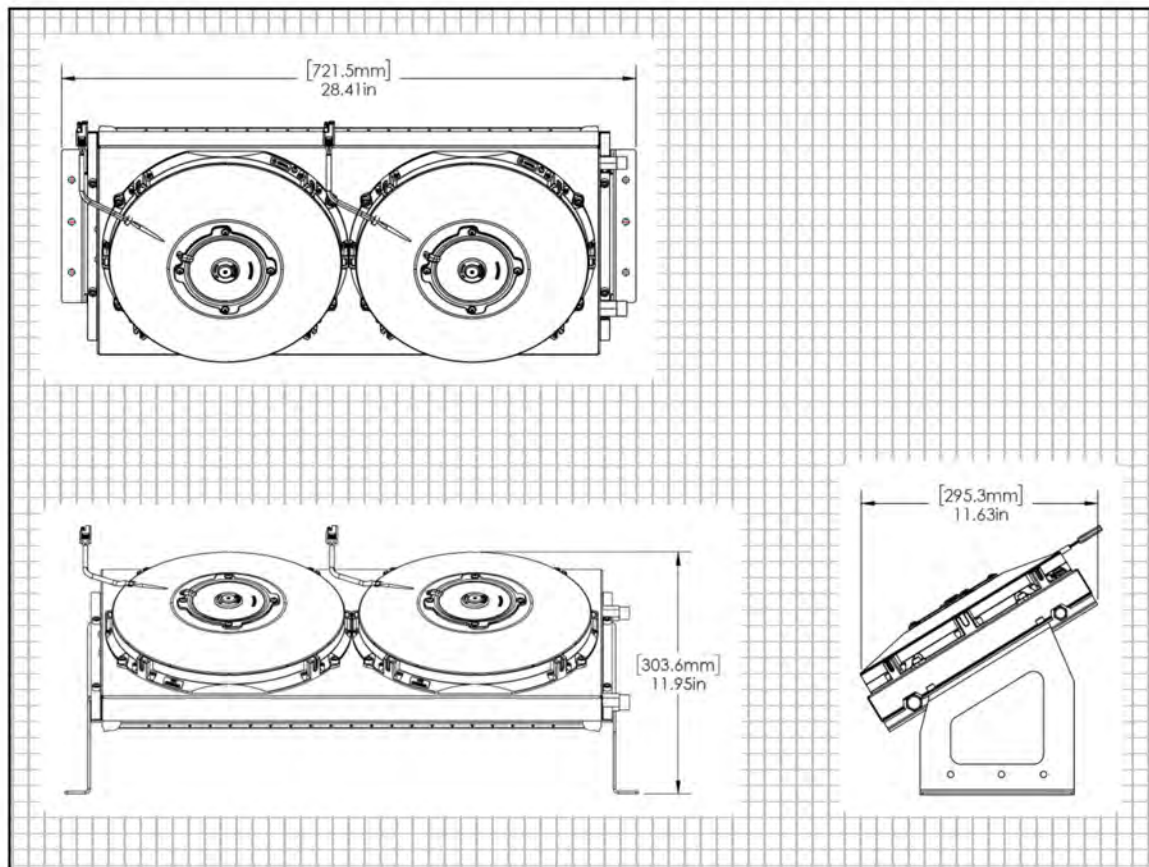

PRODUCT DIMENSIONS

Width:

28.41 in
[721.5 mm]

Height:

11.95 in
[303.6 mm]

Depth:

11.63 in
[295.3 mm]

SCAN FOR MORE INFORMATION

