

89171400-2

- 24V Heavy-duty Brushless DC Electric Motor
- Variable displacement compressor
- Heavy-duty cast aluminum housings
- Major components are IP65 rated

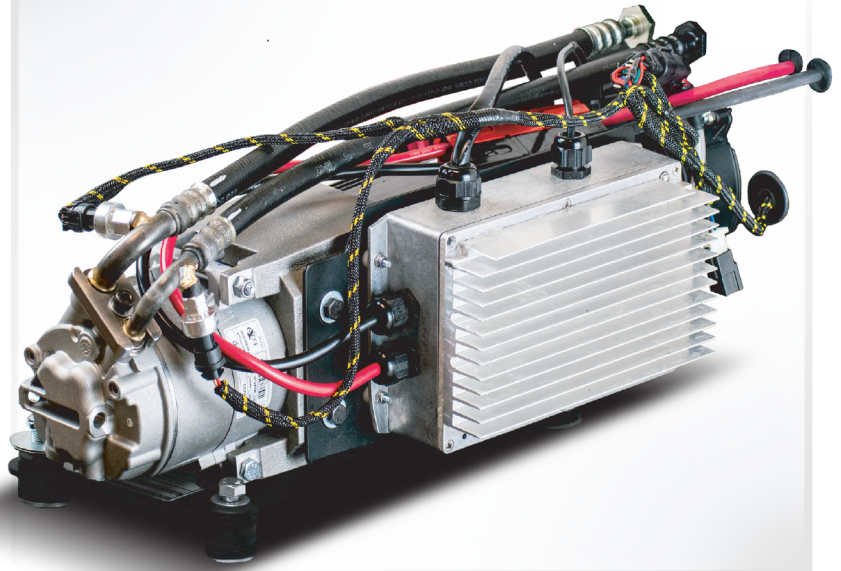

Part of the...

E-BREEZE SERIES

...of products

89171400-2 SPECIFICATIONS

CAPACITY (@100°F): 12,045 BTUH

WEIGHT: 69 lbs (31.3 kg)

Max. Energy Use: 1,440 Watts @ 24V DC @ 100°F Ambient

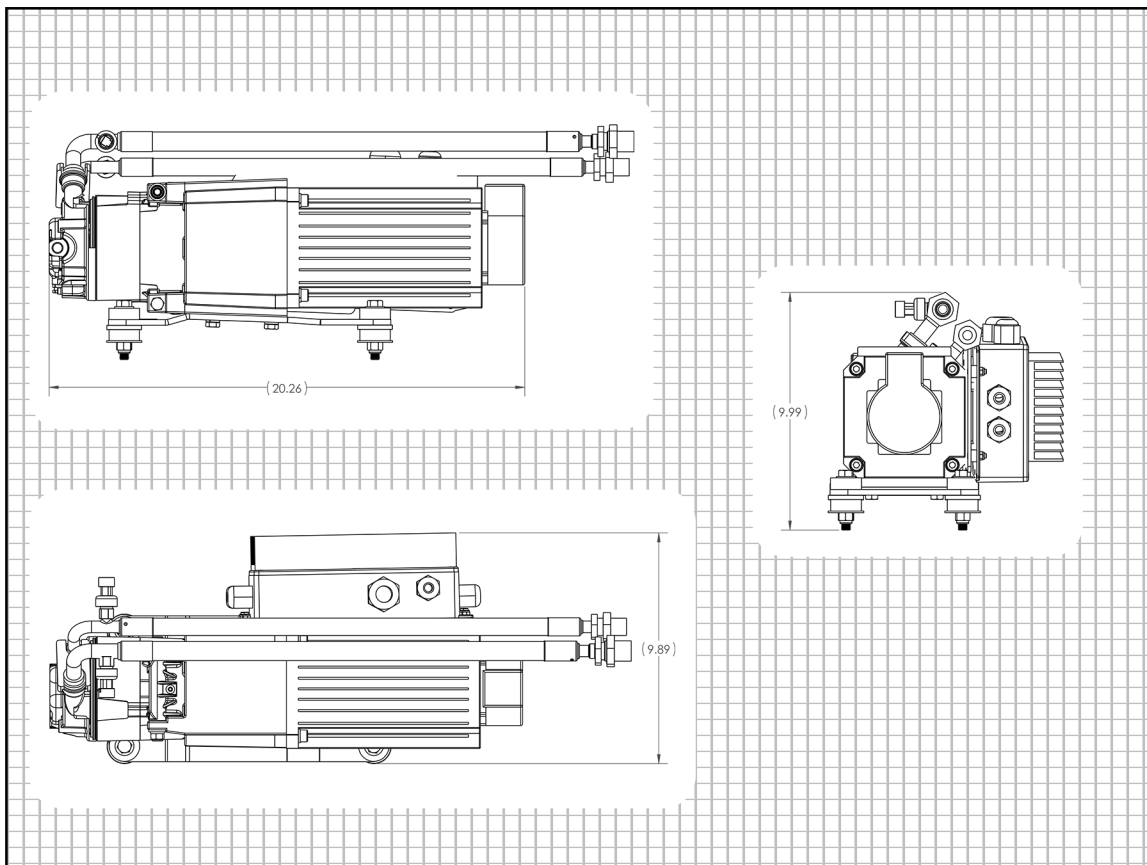

PRODUCT DIMENSIONS

Width:
9.89 in
[251.21 mm]

Height:
9.98 in
[253.4 mm]

Depth:
9.99 in
[253.75 mm]

SCAN FOR MORE INFORMATION

